

MEMBER AT 1-1, 2-2

MEMBER AT J-J, K-K

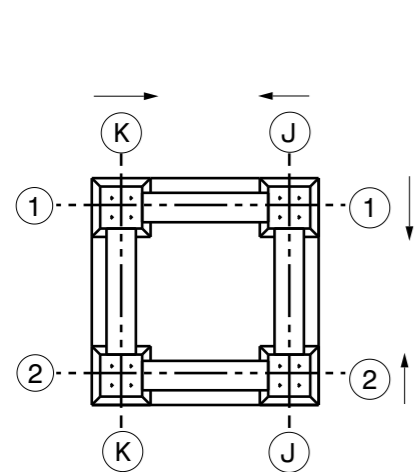

Top view

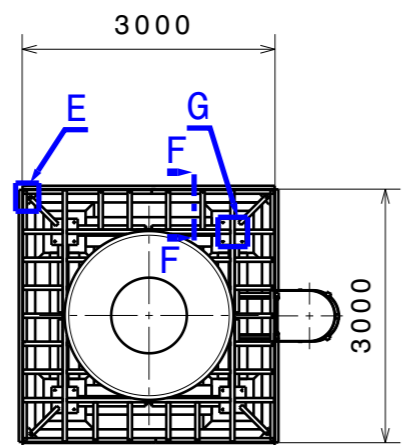

PLAN VIEW AT TANK

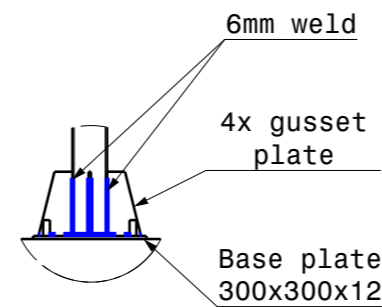

Detail A

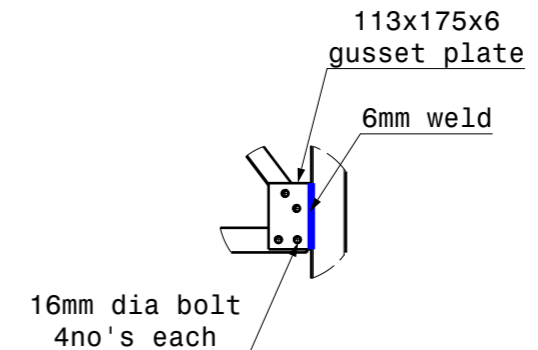

Detail B

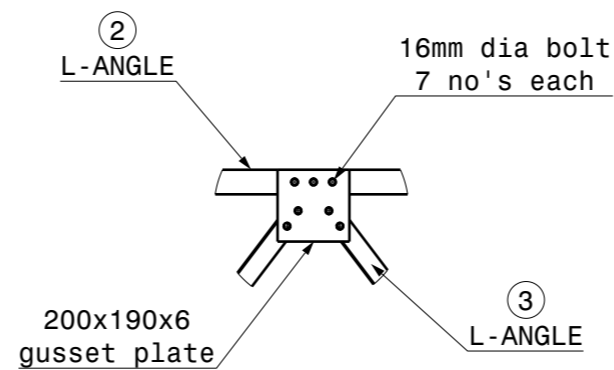

Detail C

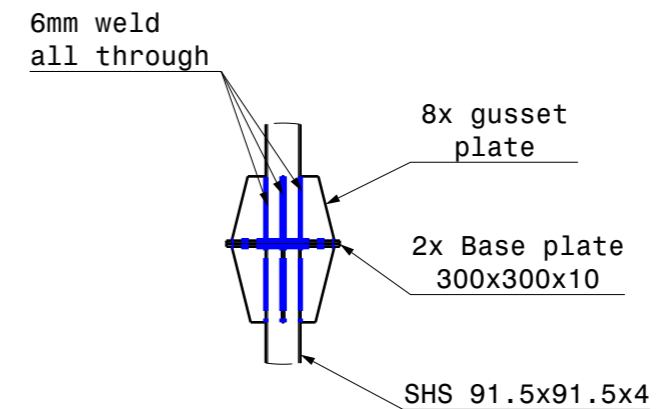

Detail D

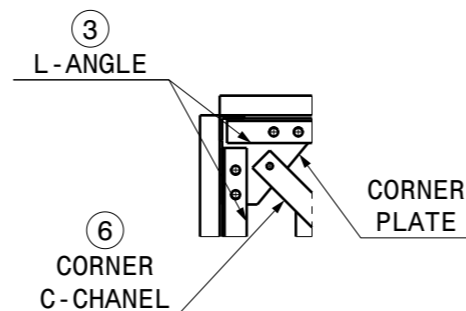

Detail E

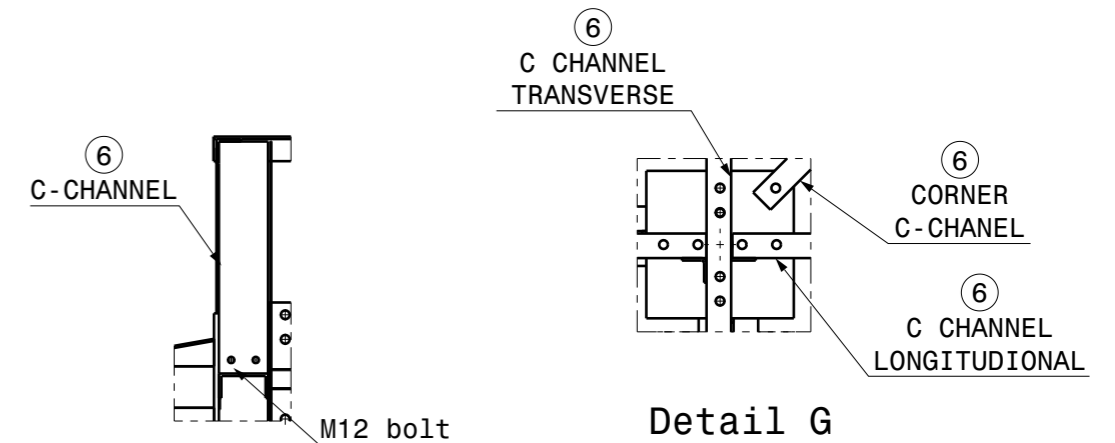

SECTION F-F

NOTES:
1. ALL DIMENSIONS ARE IN mm.

S.NO.	PARTICULAR	WEIGHT
1	SHS 91.5x91.5x4	11.4 Kg/m
2	ISA 65x65x5	4.9 Kg/m
3	ISA 50x50x5	3.0 Kg/m
4	SHS 50x50x3.2	4.5 Kg/m
5	ISA 40x40x5	3 Kg/m
6	ISMC 75x40	7.14 Kg/m

DESIGNED BY: NPS	CHATTISGARH STATE RENEWABLE ENERGY DEVELOPMENT AGENCY (CREDA)	
DATE: 7-may-2022		
CHECKED BY:	Solar Drinking Water Pump of 900 Wp, 9Mtr. Structure, 5,000 Ltr. Water Tank	
DATE:	DRAWING NUMBER MCP-9M-4P-001	
SIZE A3	WEIGHT (kg)	SHEET 2/7
SCALE	V1	

This drawing is our property; it can't be reproduced or communicated without our written agreement.

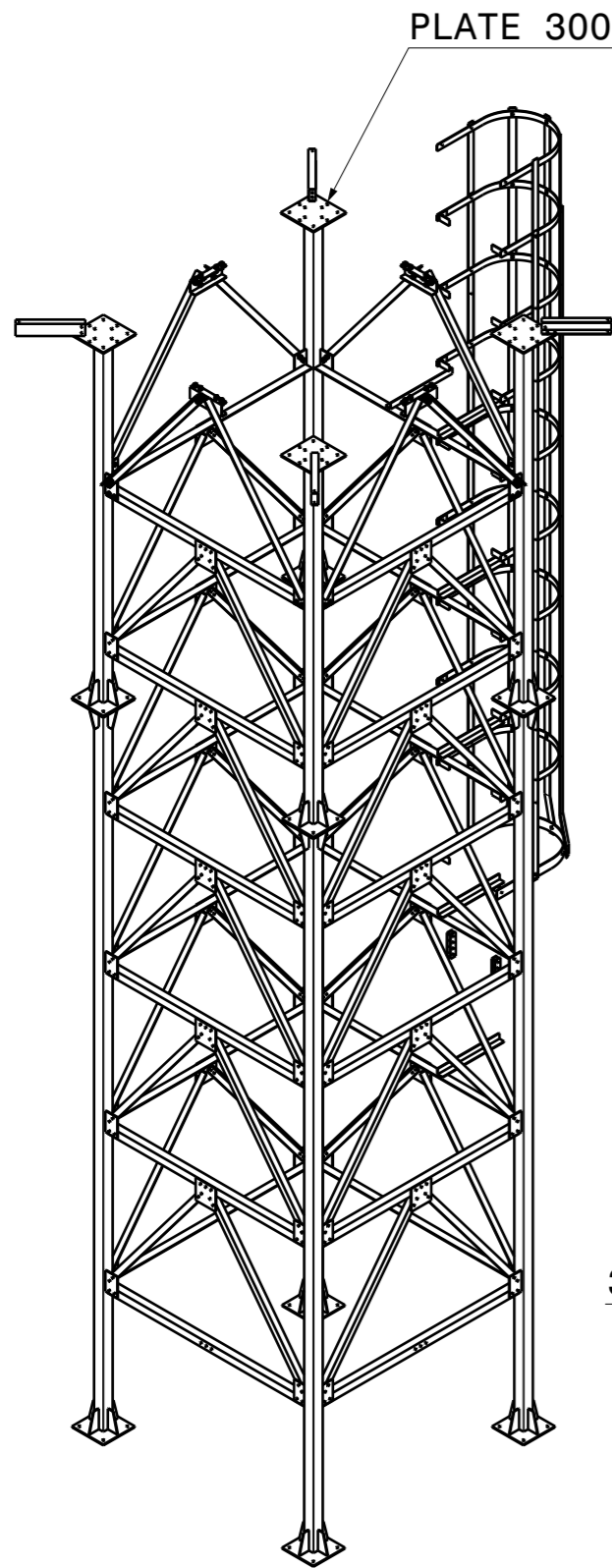

Isometric view

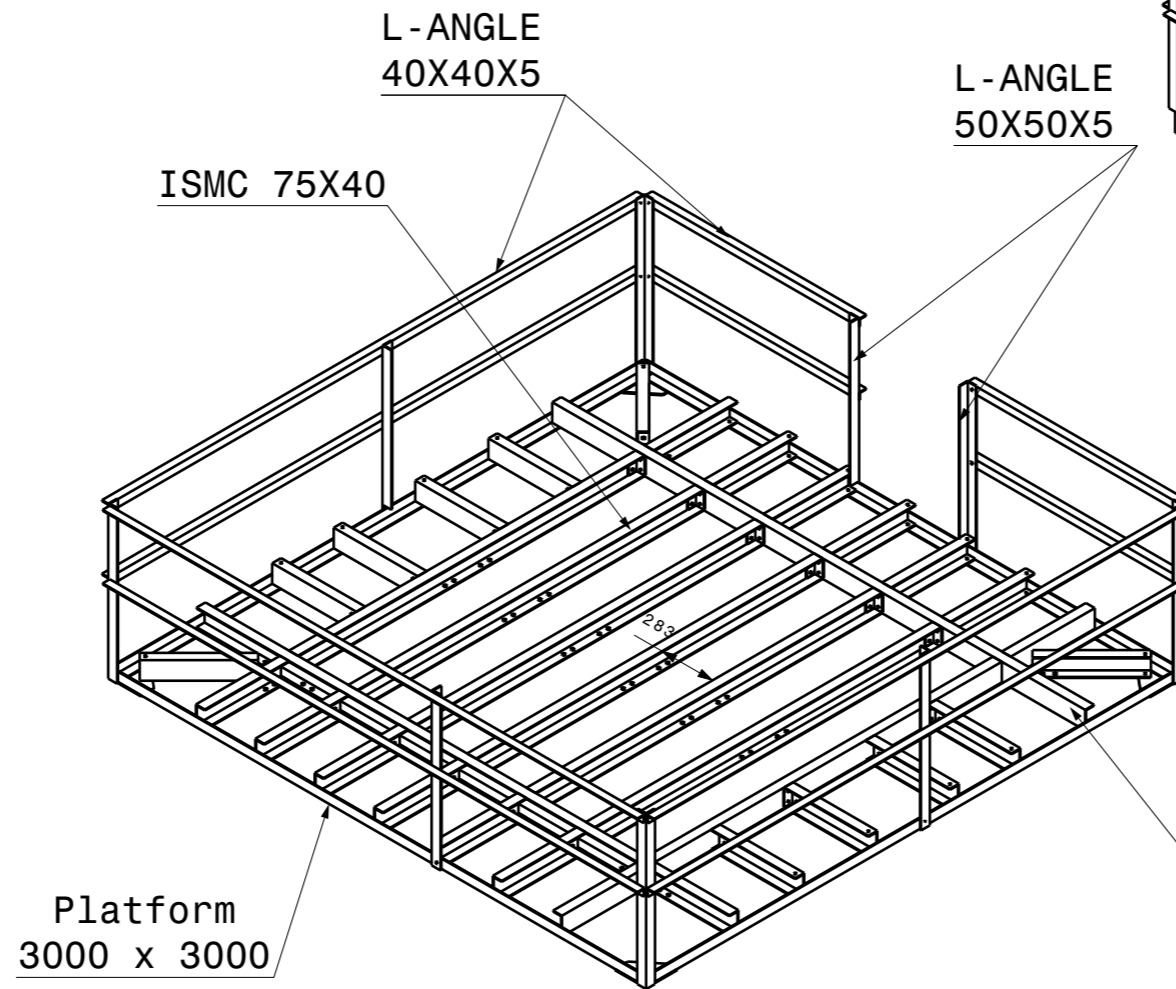

Isometric view of platform

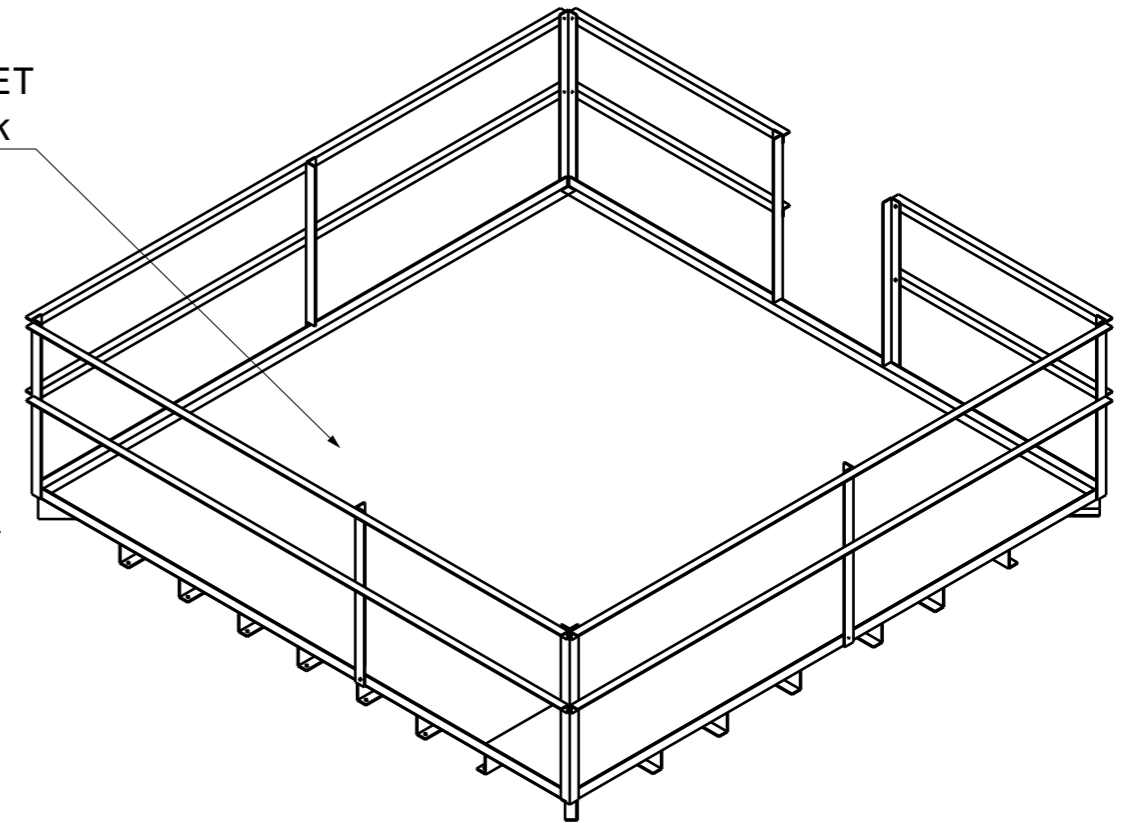

Isometric view of platform with 1.2thk GI sheet

NOTES:
1. ALL DIMENSIONS ARE IN mm.

DESIGNED BY: NPS		CHATTISGARH STATE RENEWABLE ENERGY DEVELOPMENT AGENCY (CREDA)	
DATE: 7-may-2022			
CHECKED BY:		Solar Drinking Water Pump of 900 Wp, 9Mtr. Structure, 5,000 Ltr. Water Tank	
DATE:			
SIZE A3		DRAWING NUMBER MCP-9M-4P-001	SHEET 5/7
SCALE	WEIGHT (kg)	V1	
This drawing is our property; it can't be reproduced or communicated without our written agreement.			

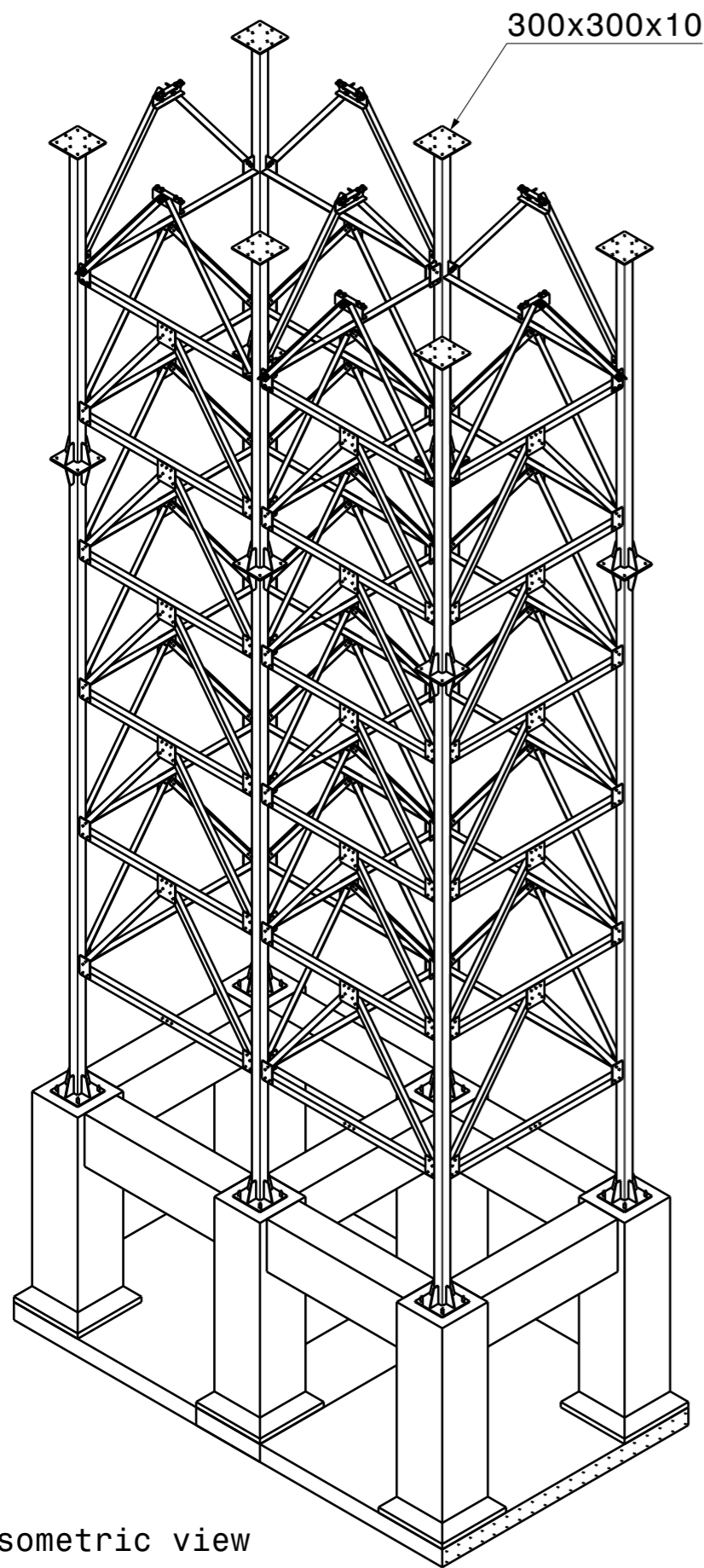

Isometric view

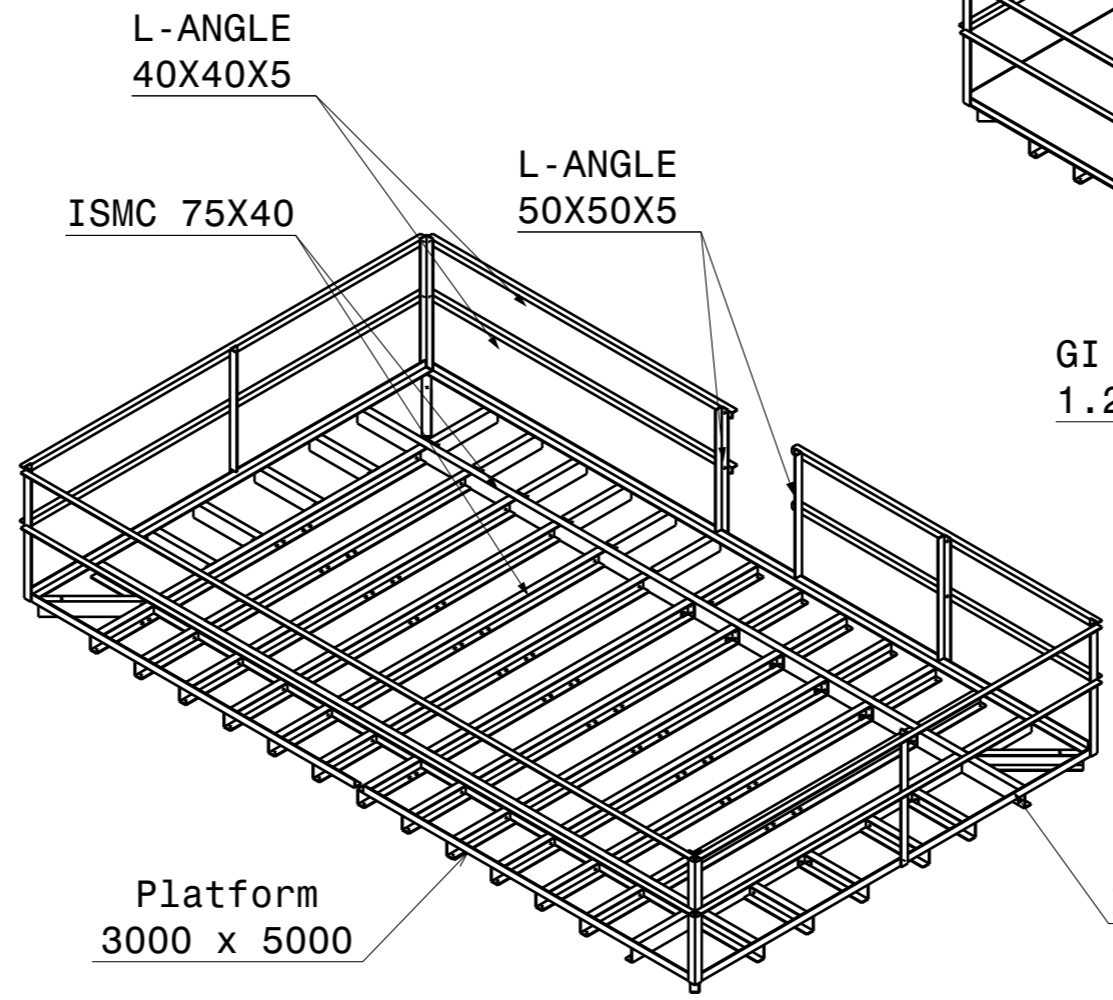

Isometric view of platform

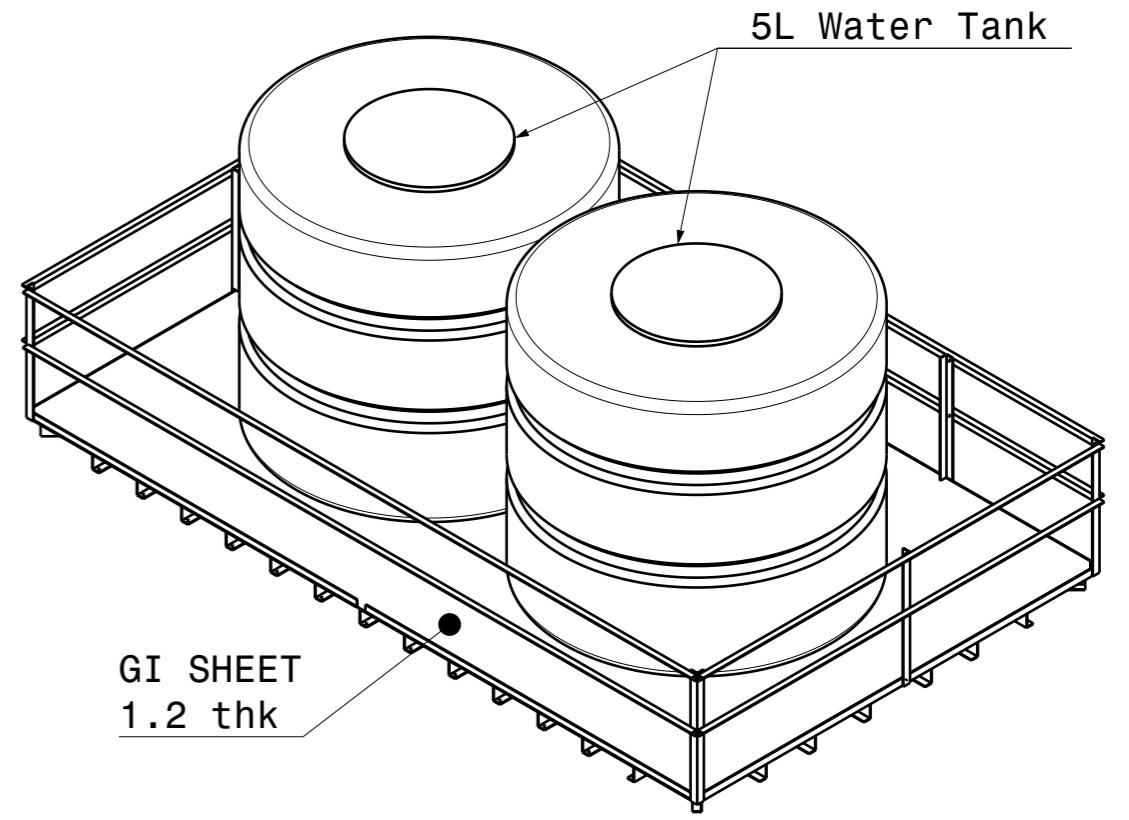

Isometric view of platform with 1.2thk GI sheet

NOTES:
1. ALL DIMENSIONS ARE IN mm.

DESIGNED BY: NPS	CHATTISGARH STATE RENEWABLE ENERGY DEVELOPMENT AGENCY (CREDA)		
DATE: 7-may-2022			
CHECKED BY:	Solar Drinking Water Pump of 1200 Wp, 9Mtr. Structure, 10,000 Ltr. Water Tank		
DATE:			
SIZE A3	WEIGHT (kg)	DRAWING NUMBER MCP-9M-4P-002	SHEET 5/7
This drawing is our property; it can't be reproduced or communicated without our written agreement.			
			V1

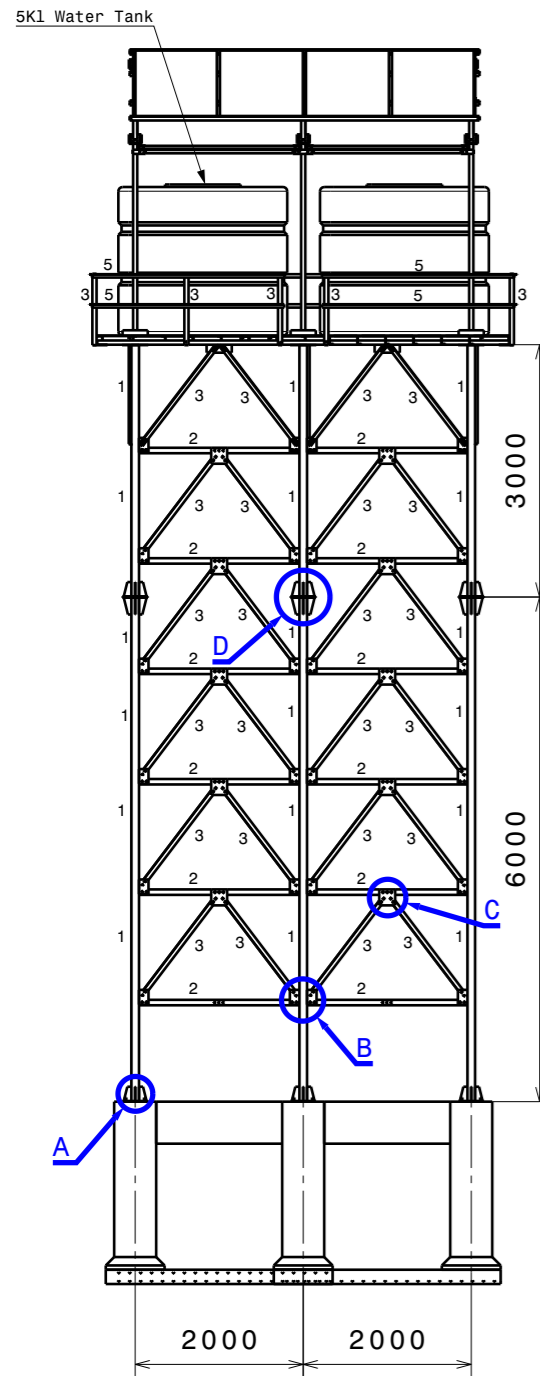

MEMBER AT 1-1, 2-2

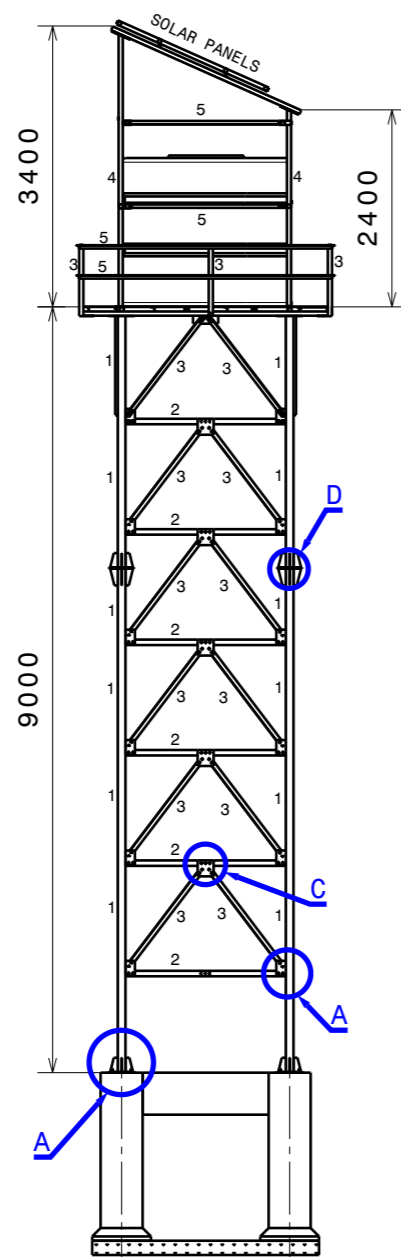

MEMBER AT J-J, K-K, L-L

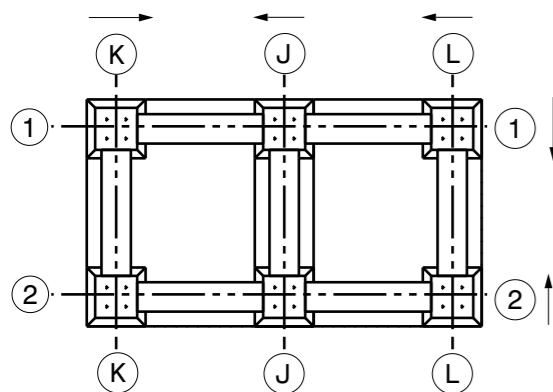

Top view

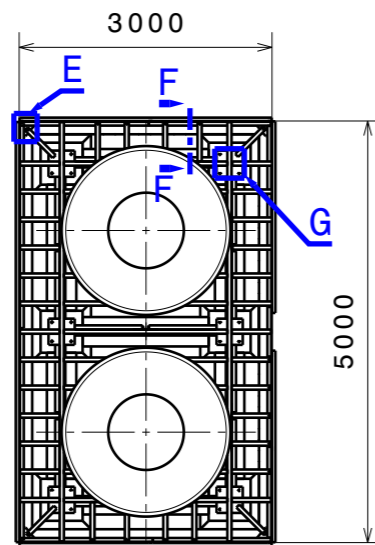

PLAN VIEW AT TANK

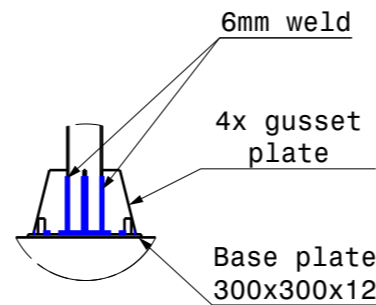

Detail A

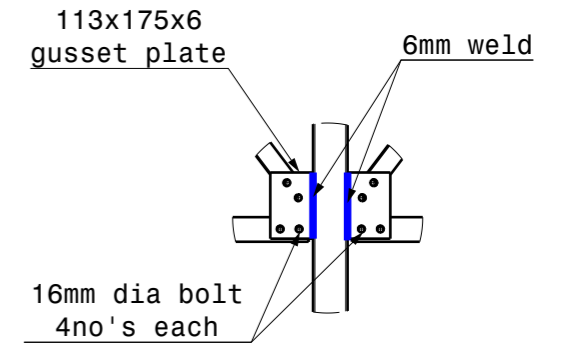

Detail B

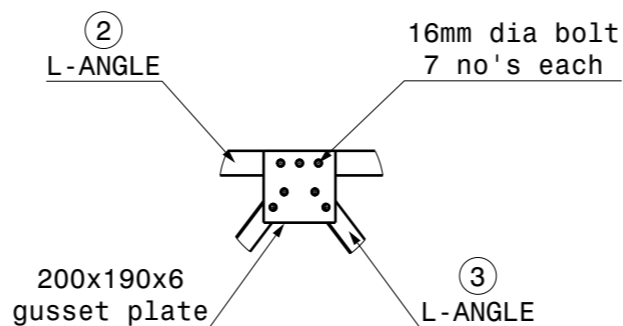

Detail C

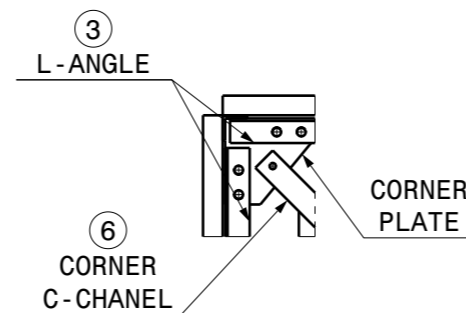

Detail E

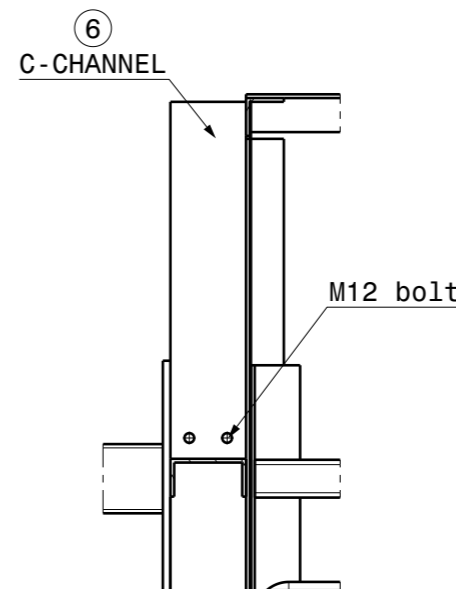

Section F-F

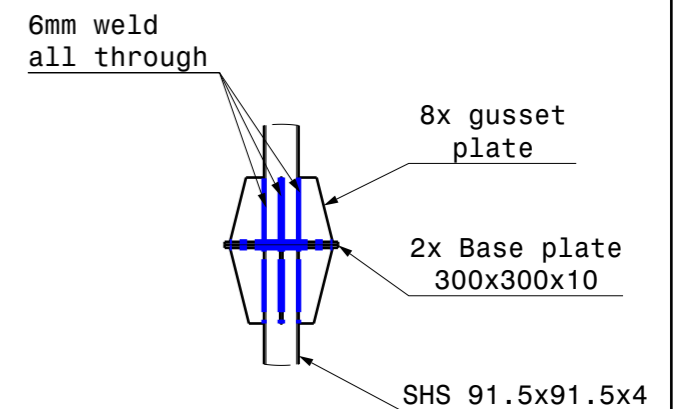

Detail D

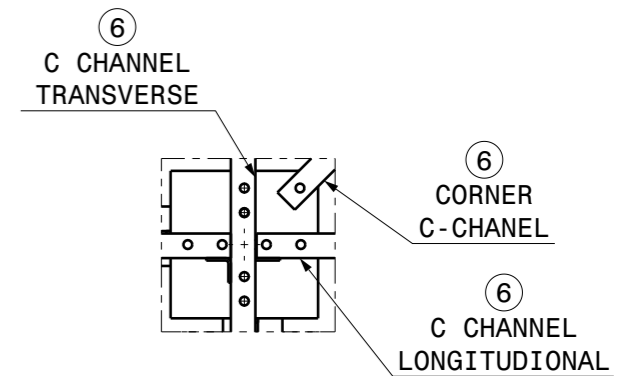

Detail G

NOTES:
1. ALL DIMENSIONS ARE IN mm.

S.NO.	PARTICULAR	WEIGHT
1	SHS 91.5x91.5x4	11.4 Kg/m
2	ISA 65x65x5	4.9 Kg/m
3	ISA 50x50x5	3.0 Kg/m
4	SHS 50x50x3.2	4.5 Kg/m
5	ISA 40x40x5	3 Kg/m
6	ISMC 75x40	7.14 Kg/m

DESIGNED BY: NPS	CHATTISGARH STATE RENEWABLE ENERGY DEVELOPMENT AGENCY (CREDA)		
DATE: 7-may-2022			
CHECKED BY:			
DATE:			
SIZE: A3			
SCALE:	WEIGHT (kg)	DRAWING NUMBER: MCP-9M-4P-002	SHEET: 2/7
This drawing is our property; it can't be reproduced or communicated without our written agreement.			V1

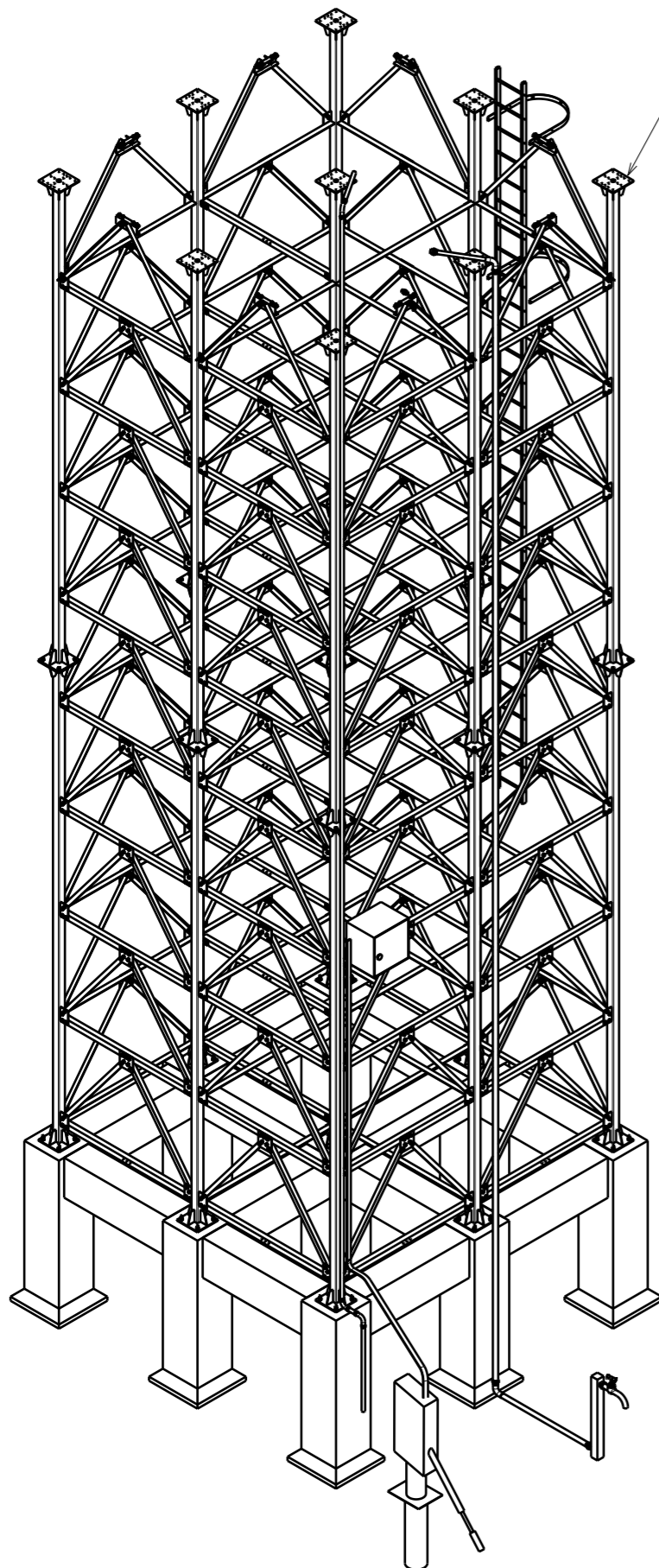

Isometric view
OF STRUCTRE

PLATE 300X300X10

L-ANGLE
40X40X5

L-ANGLE
50X50X5

Platform
5000 x 5000

Isometric view
OF PLATFORM

GI SHEET 1.2thk

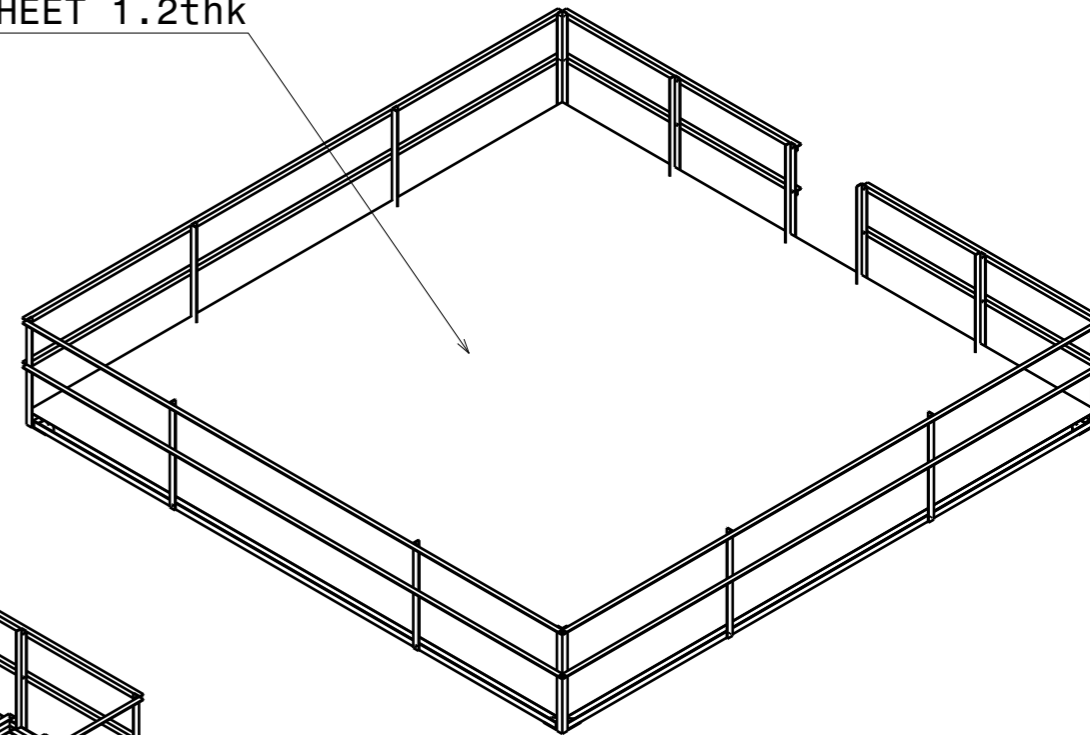

Isometric view

ISMC 75X40

NOTES:
1.ALL DIMENSIONS ARE IN mm.

DESIGNED BY: AKCH		CHATTISGARH STATE RENEWABLE ENERGY DEVELOPMENT AGENCY (CREDA)	
DATE: 7.MAY.2022			
CHECKED BY:		Solar Drinking Water Pump of 1200 Wp, 12Mtr. Structure, 10,000 Ltr. Water Tank	
DATE:			
SIZE A3		DRAWING NUMBER MCP-12M-4P-003	
SCALE	WEIGHT (kg)	SHEET 5/7	
This drawing is our property; it can't be reproduced or communicated without our written agreement.			

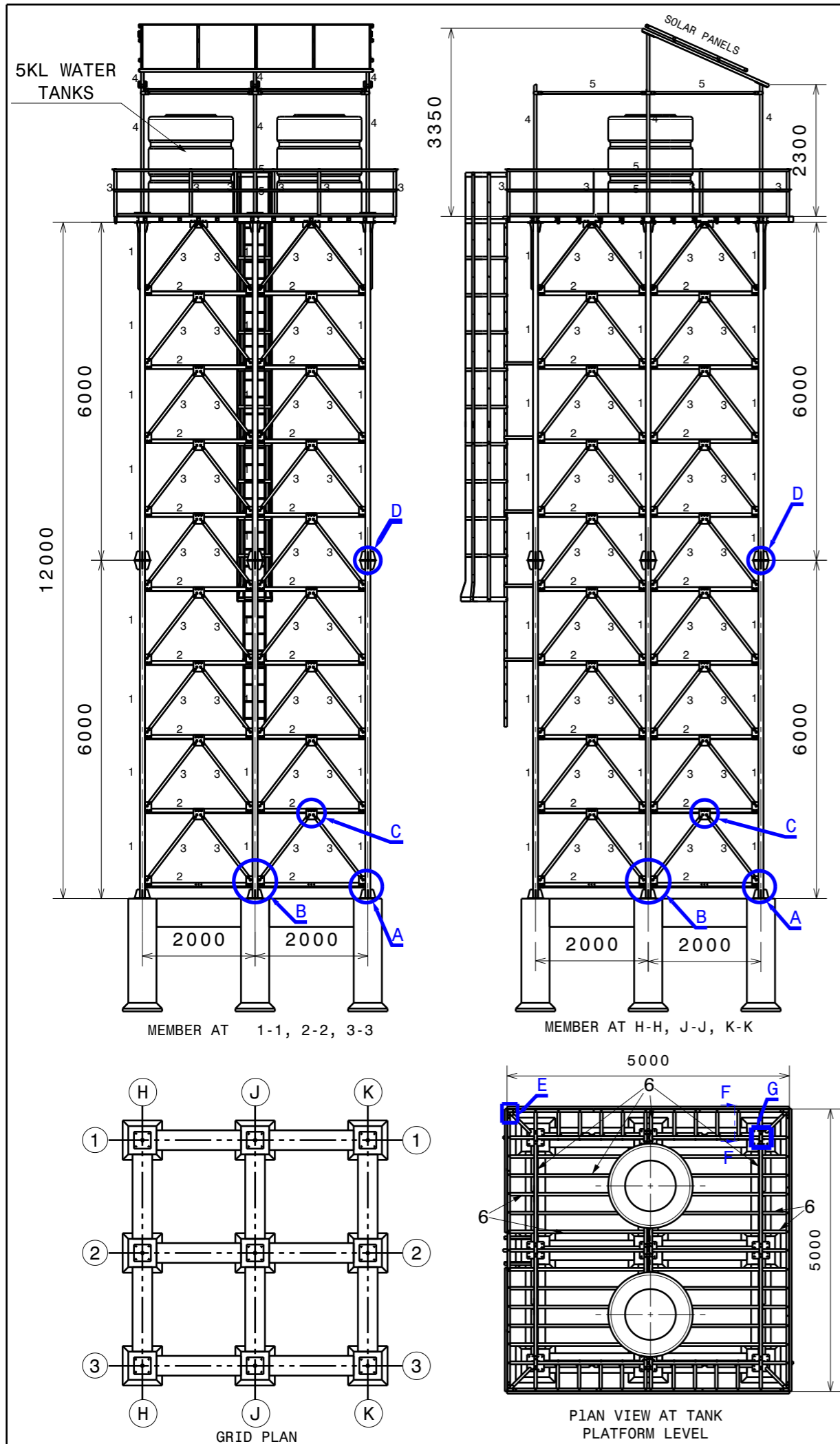

S.NO.	PARTICULAR	WEIGHT
1	SHS 91.5x91.5x4	11.4 Kg/m
2	ISA 65x65x5	4.9 Kg/m
3	ISA 50x50x5	3.0 Kg/m
4	SHS 50x50x3.2	4.5 Kg/m
5	ISA 40x40x5	3 Kg/m
6	ISMC 75x40	7.14 Kg/m

NOTES:
1. ALL DIMENSIONS ARE IN mm

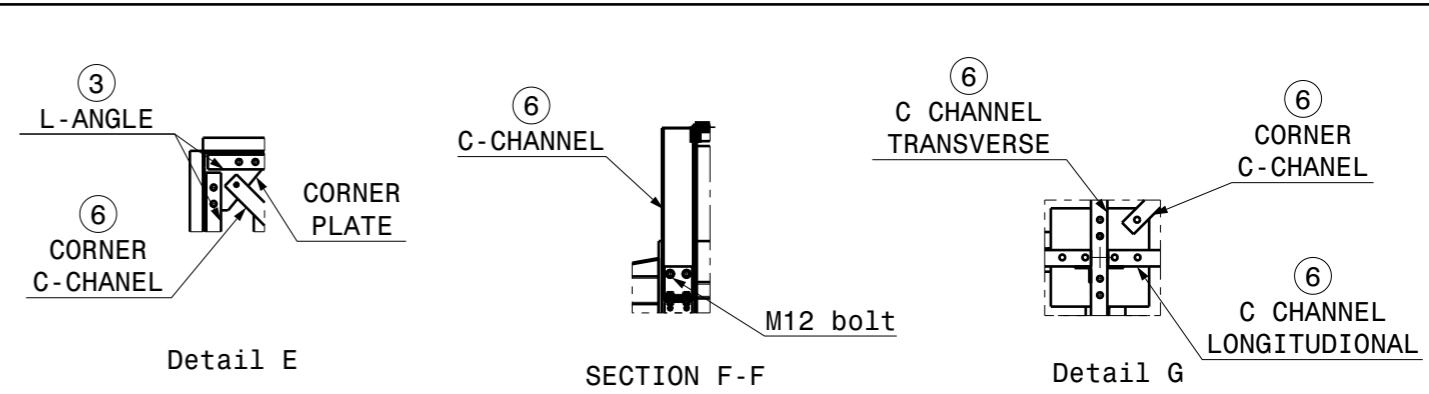
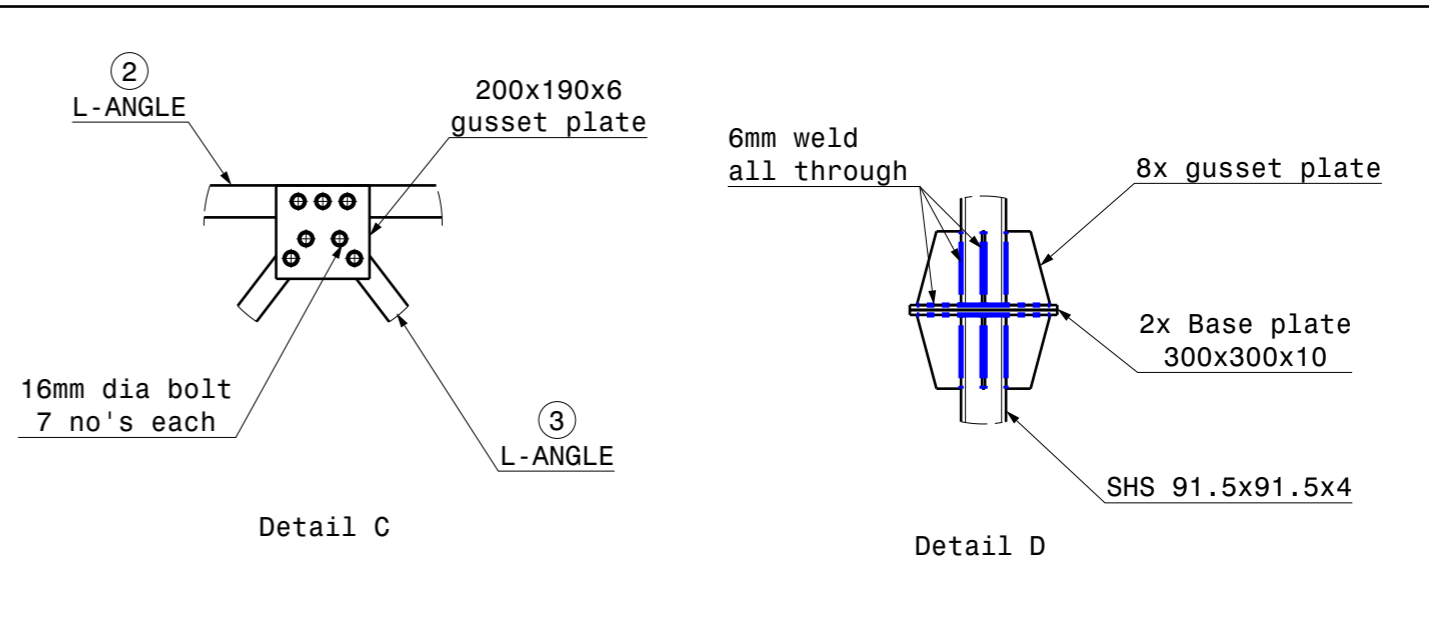
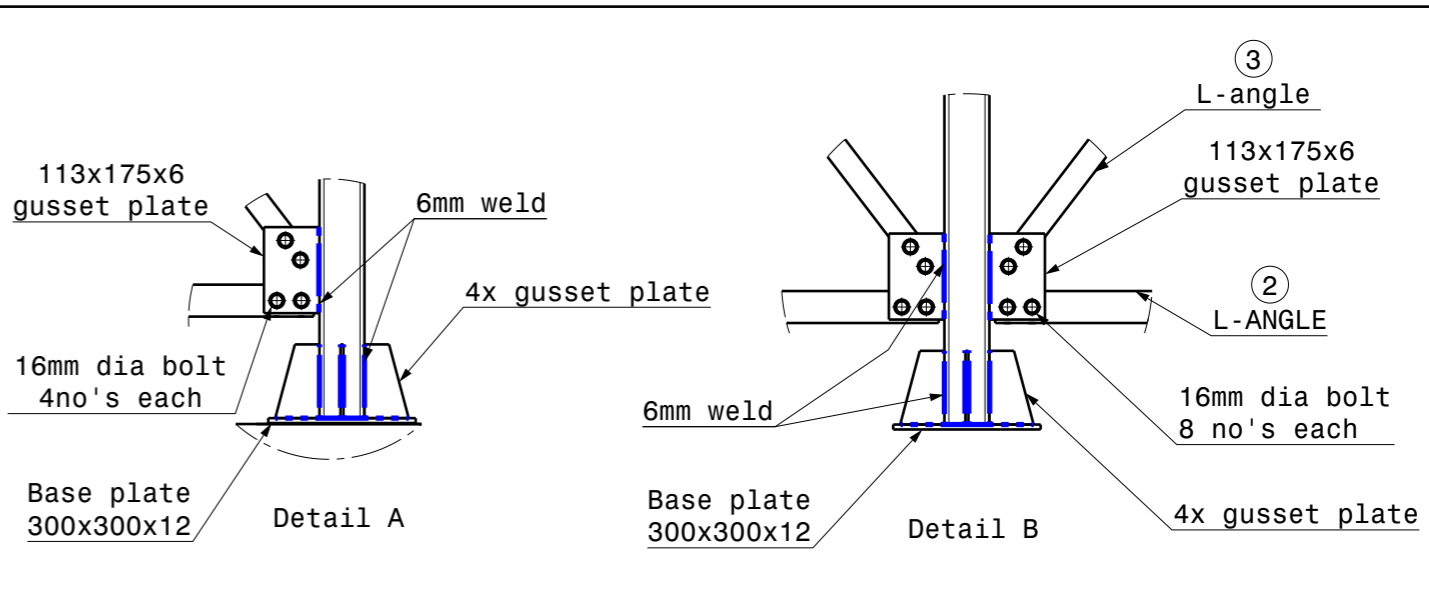

DESIGNED BY: AKCH	CHATTISGARH STATE RENEWABLE ENERGY DEVELOPMENT AGENCY (CREDA)
DATE: 7.MAY.2022	
CHECKED BY:	
DATE:	
SIZE: A3	
SCALE:	
WEIGHT (kg):	
DRAWING NUMBER: MCP-12M-4P-003	
SHEET: 2/7	
	V2

Solar Drinking Water Pump of 1200 Wp, 12Mtr. Structure, 10,000 Ltr. Water Tank

This drawing is our property; it can't be reproduced or communicated without our written agreement.

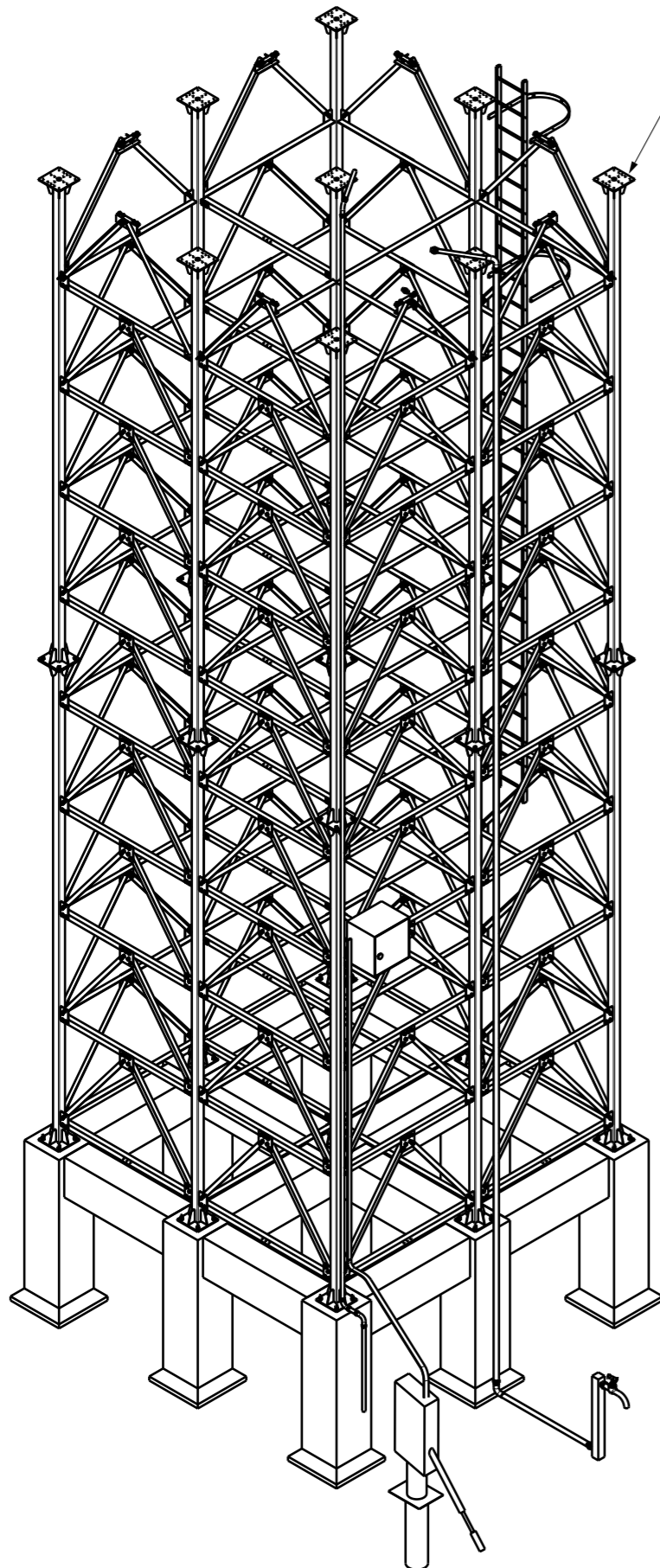

Isometric view
OF STRUCTRE

PLATE 300X300X10

L-ANGLE
40X40X5

L-ANGLE
50X50X5

Platform
5000 x 5000

Isometric view
OF PLATFORM

GI SHEET 1.2 thk

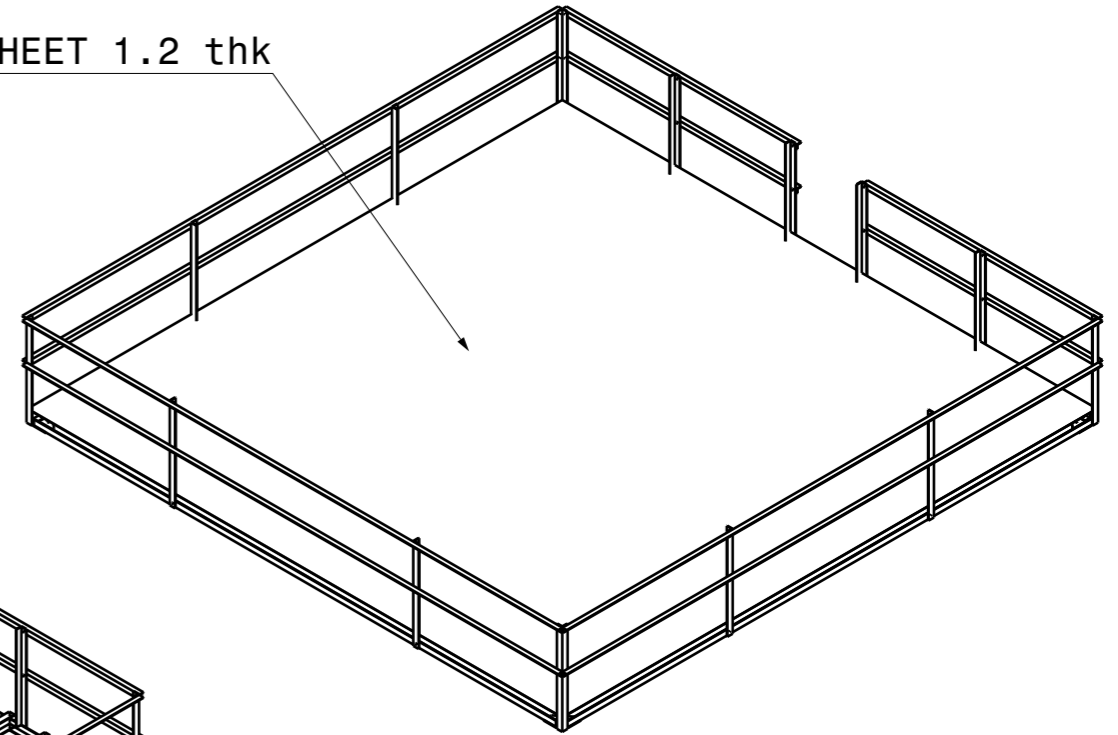

Isometric view

ISMC 75X40

NOTES:
1.ALL DIMENSIONS ARE IN mm.

DESIGNED BY: AKCH		CHATTISGARH STATE RENEWABLE ENERGY DEVELOPMENT AGENCY (CREDA)	
DATE: 7.MAY.2022			
CHECKED BY:		Solar Drinking Water Pump of 1200 Wp, 12Mtr. Structure, 12,000 Ltr. Water Tank	
DATE:			
SIZE A3		DRAWING NUMBER MCP-12M-4P-002	
SCALE	WEIGHT (kg)	SHEET 5/7	
This drawing is our property; it can't be reproduced or communicated without our written agreement.			

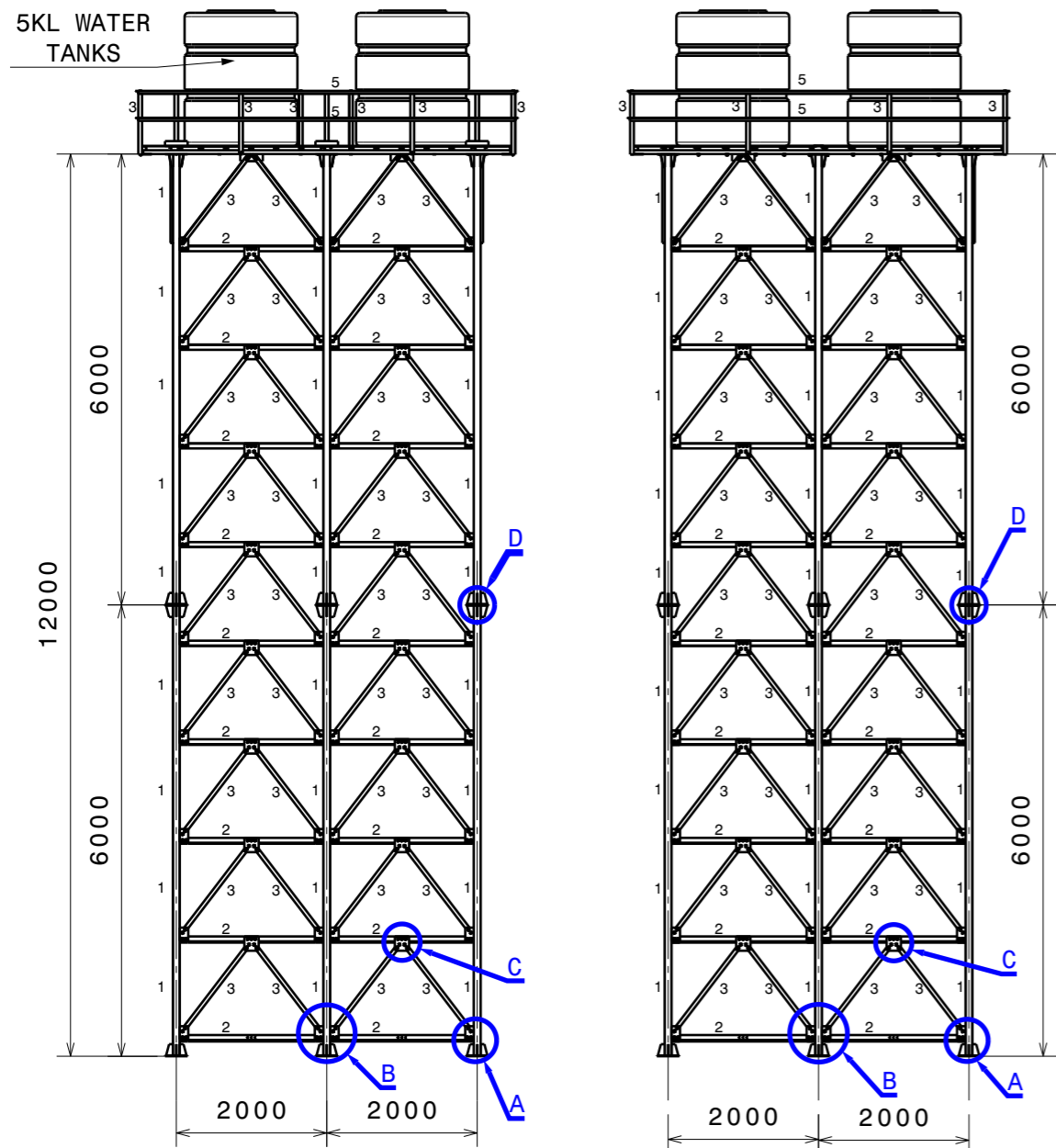

MEMBER AT
1-1, 2-2, 3-3

MEMBER AT
H-H, J-J, K-K

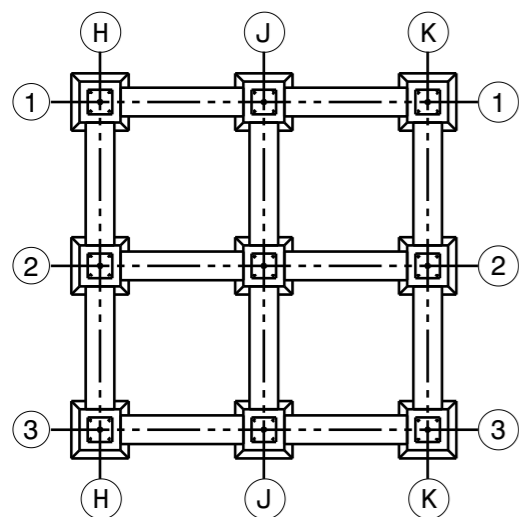

GRID PLAN

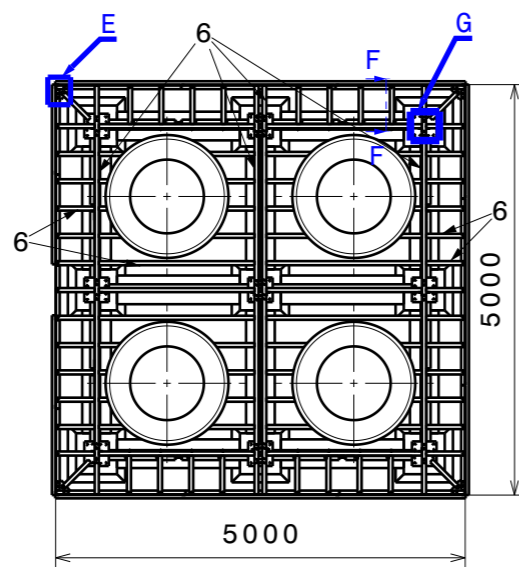

PLAN VIEW AT TANK
PLATFORM LEVEL

S.NO.	PARTICULAR	WEIGHT
1	SHS 100x100x5	14.4 Kg/m
2	ISA 65x65x5	4.9 Kg/m
3	ISA 50x50x5	3.0 Kg/m
4	SHS 50x50x3.2	4.5 Kg/m
5	ISA 40x40x5	3 Kg/m
6	ISMC 100x50	9.56 Kg/m

NOTES:
1. ALL DIMENSIONS ARE IN mm

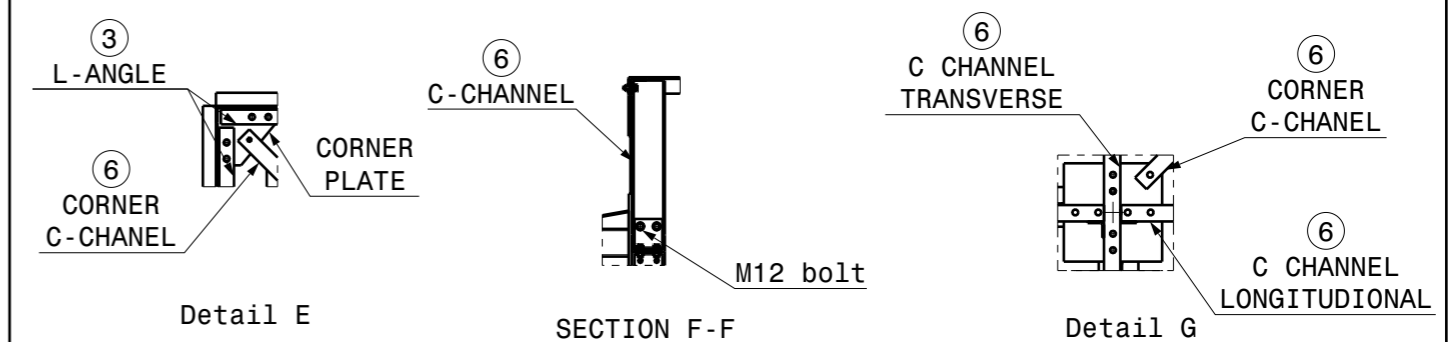
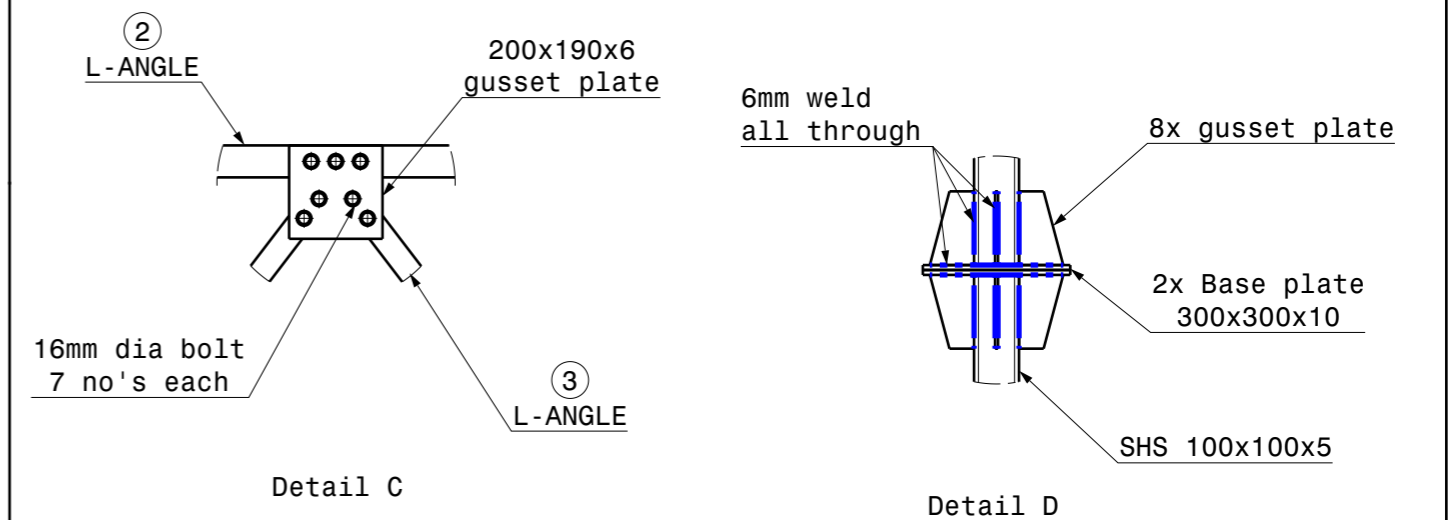
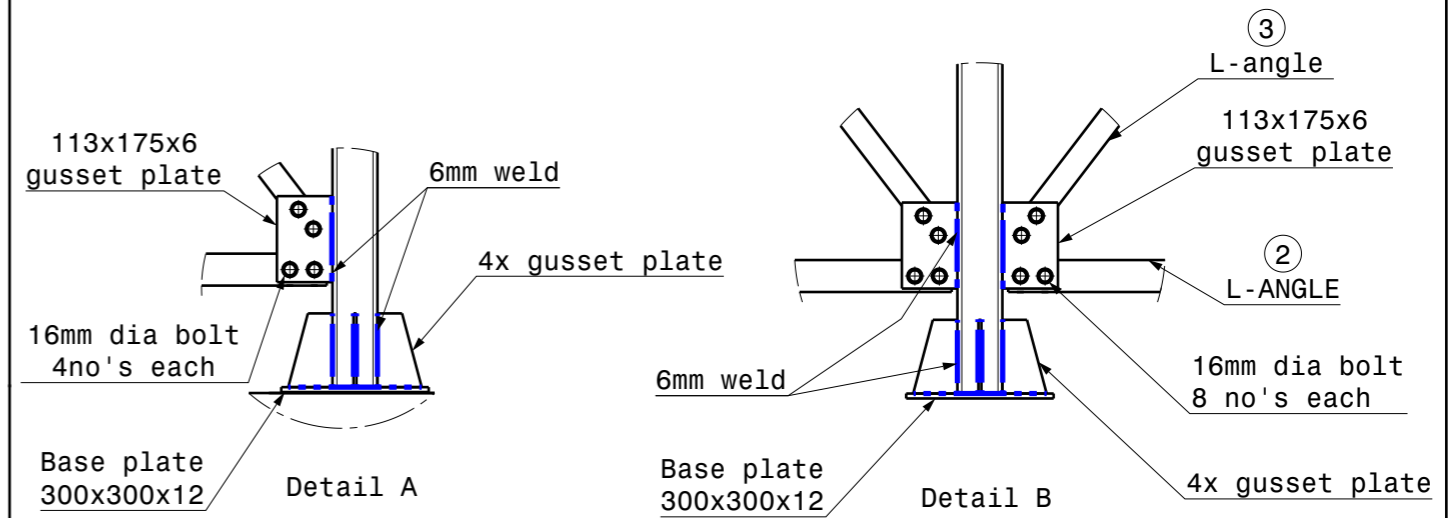

DESIGNED BY: AKCH		CHATTISGARH STATE RENEWABLE ENERGY DEVELOPMENT AGENCY (CREDA)	
DATE: 7. MAY. 2022			
CHECKED BY:		DATE:	
SIZE: A3		Solar Drinking Water Pump of 1800 Wp, 12Mtr. Structure, 20,000 Ltr. Water Tank	
SCALE	WEIGHT (kg)	DRAWING NUMBER	SHEET
		MCP-12M-6P-001	2/7

This drawing is our property; it can't be reproduced or communicated without our written agreement.

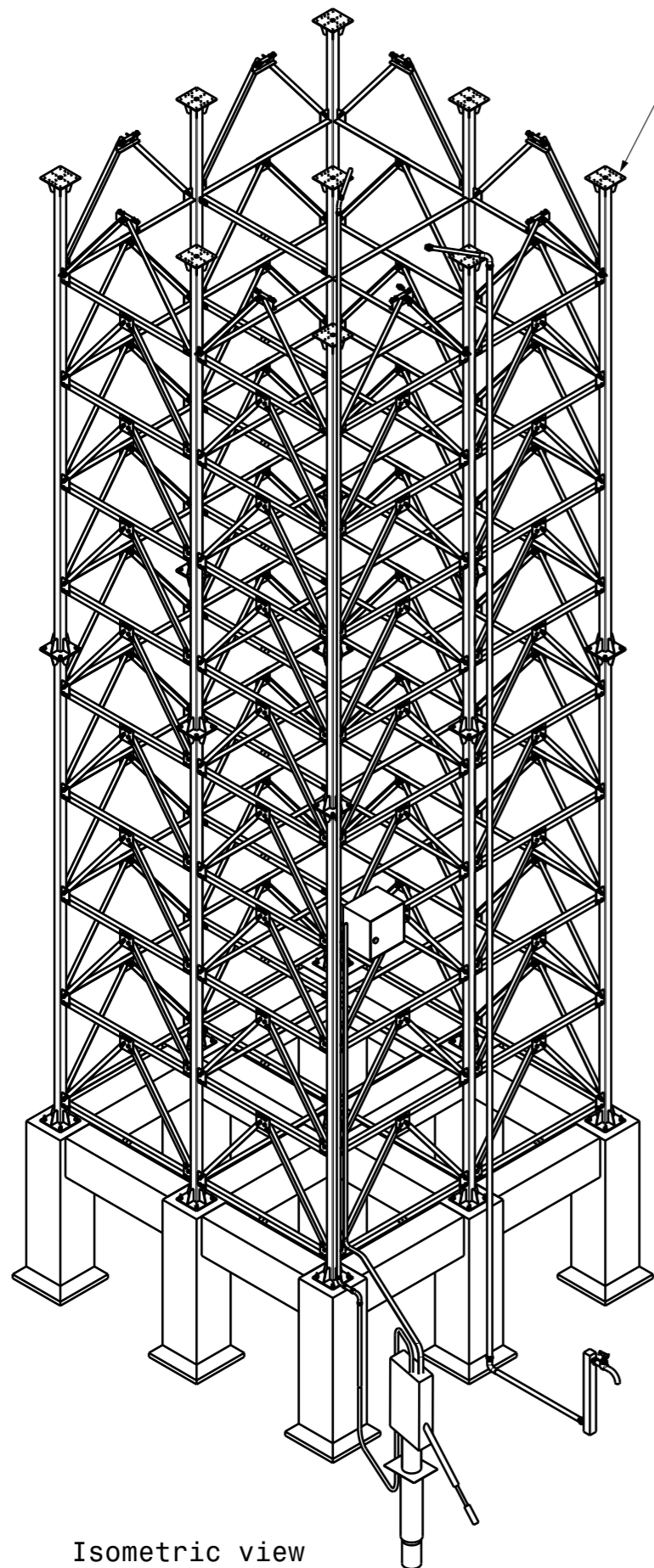

Isometric view
OF STRUCTRE

PLATE 300X300X10

40x40x5 1 angle

50x50x5 1
angle

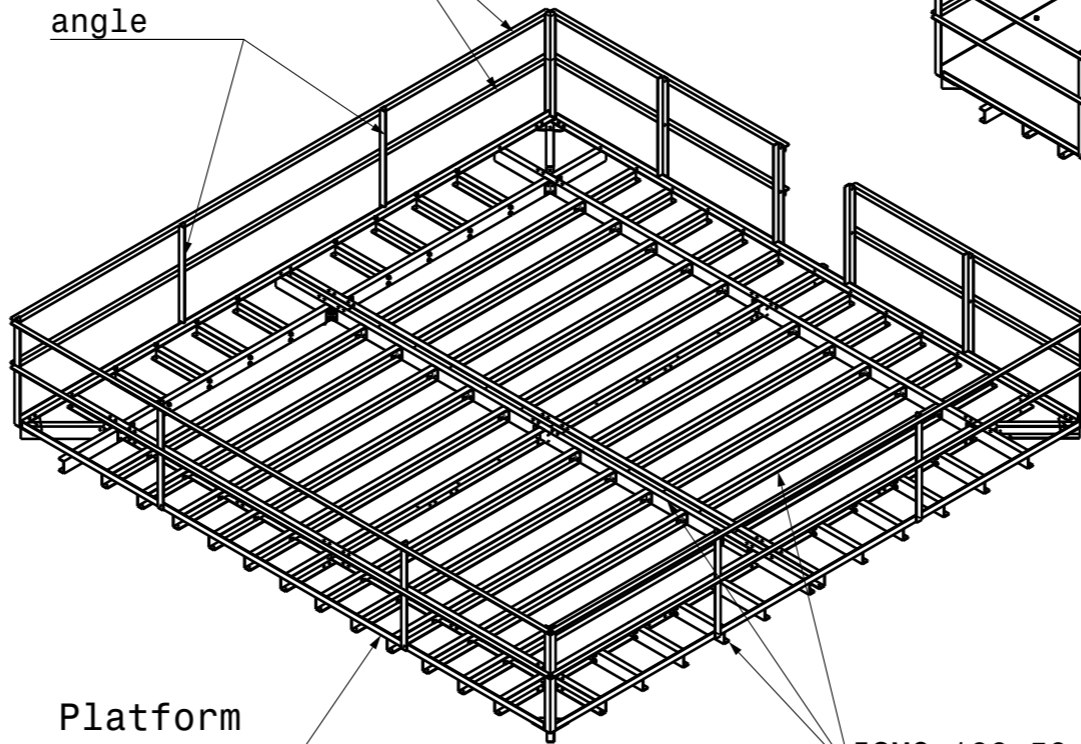

Platform
5000 x 5000

Isometric view
OF PLATFORM

GI SHEET 1.2 thk

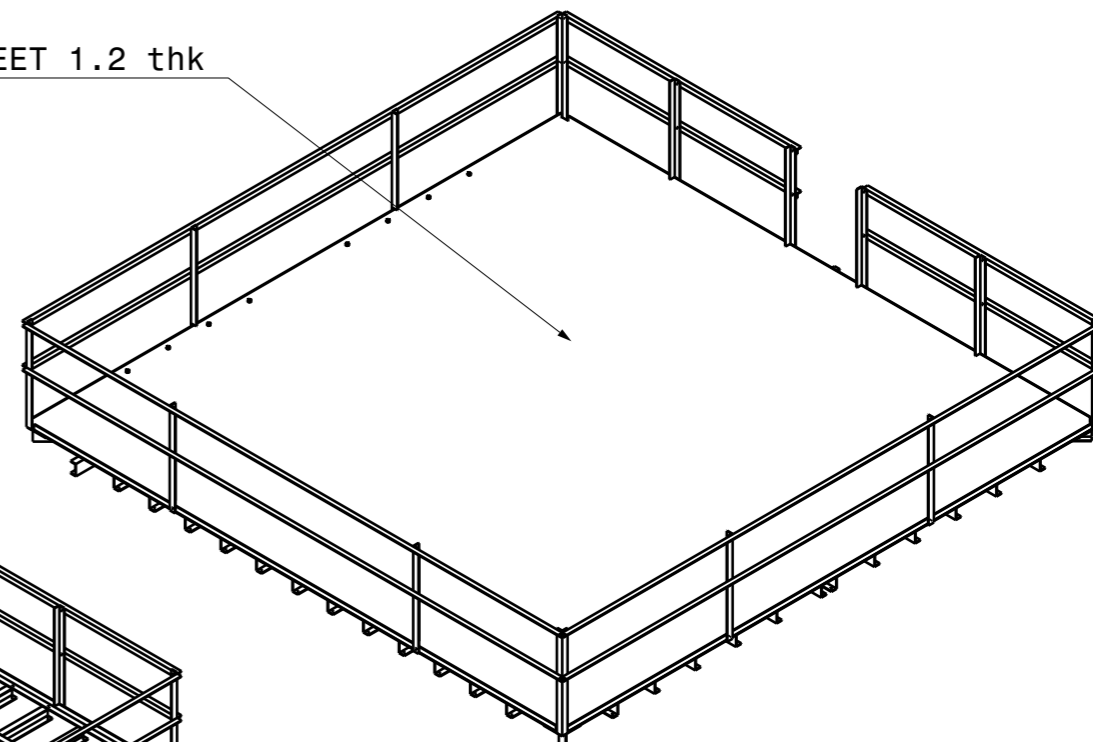

Isometric view
OF PLATFORM

ISMC 100x50

NOTES:
1.ALL DIMENSIONS ARE IN mm.

DESIGNED BY: AKCH	CHATTISGARH STATE RENEWABLE ENERGY DEVELOPMENT AGENCY (CREDA)		
DATE: 7.MAY.2022			
CHECKED BY:			
DATE:			
SIZE A3	Solar Drinking Water Pump of 1800 Wp, 12Mtr. Structure, 20,000 Ltr. Water Tank		
SCALE	WEIGHT (kg)	DRAWING NUMBER MCP-12M-6P-001	SHEET 5/7
This drawing is our property; it can't be reproduced or communicated without our written agreement.			